

# ALTUNTOP

ALTUNTOP

## TECHNICAL TABLE

	ATPD 40	ATPD 50
Tepsi Sayısı- Number of Trays(pcs) Nombre De Plateaux (quntité)-Количество противней (шт)	10	10
Tepsi Ölçüleri - Tray Dimensions (mm) Taille du plateau - Размеры противней (мм)	400x600	530x650 500x700
Elektrikli Fırınlr İçin Genişlik - Width for Electric Ovens (mm) Largeur pour fours électriques - Ширина для электрических духовок (мм)	1005	1100
Doğalgazlı Fırınlr İçin Genişlik - Width for Gas Ovens(mm) Largeur pour fours à gaz - Ширина для газовых духовок (мм)	1140	1265
Derinlik - Depth (mm) Profondeur - Глубина (мм)	1270	1415
Maksimum Derinlik - Max.Depth (mm) Max.Hauteur - Макс. глубина (мм)	1500	1635
Yükseklik-Height (mm) Hauteur - Высота (мм)	2060	2060
Maksimum Yükseklik- H(mm) - Max.Height Max.Hauteur- H(mm) - Макс. высота (мм)	2250	2250
Pişirme Alanı - Baking Area (m <sup>2</sup> ) Surface De Cuisson - Площадь выпечки (м <sup>2</sup> )	2,4	3,5
Min. Tavan Yüksekliği - Min. Ceiling Height (mm) Min. Hauteur du plafond - Мин. высота помещения (мм)	2550	2550
Enerji Kaynakları - Energy Source Source D'énergie - Источники энергии	GAS Diesel Electric / GAZ Dizel Elektrik / ГАЗ Дизель Электрический	
Toplam Elektrik Gücü (kW) - Total Electrical Power Puissance Electrique Totale (kW)-Общая электрическая мощность (кВт)	1,5 kW	1,5 kW
Elektrikli Fırınlr İçin Toplam Elektrik Gücü(kw)-Resistance Power for Electric Oven - Consommation Electrique Du Four(kw) - Общая электрическая мощность для электрических печей(кВт)	22,5 kW	26 kW
Gaz Basıncı - Gas Pressure (mbar) Pression du gaz (mbar) - Давление газа (мбар)	21	21
Brülör Modeli - Burner Model Modèle de brûleur - Модель горелки	Riello	Riello
Elektrik Voltajı - Electric Voltage Tension électrique - Электрическое напряжение	380	380
Kontrol Sistemi - Control System Système De Controle - Панель управления	Dijital / Manuel	Dijital / Manuel
Fırın Ağırlığı - Weight (kg) Poids(kg) - Вес печи (кг)	372	400
Gazlı fırınlar için mak. genişlik -Max. width for gas ovens Largeur maximale pour les fours à gaz-Максимальная ширина для газовых печей(мм)	1100	1270

### Mayalama Odası - Fermentation Chamber - Chambre De Fermentation - Расстойная камера

Genişlik - Width - Largeur (mm) - Ширина (мм)	1000	1100
Derinlik - Depth - Profondeur (mm) - Глубина (мм)	1240	1375
Yükseklik - Height- Hauteur (mm) - Высота (мм)	765	765
Tepsi Ölçüleri - Tray Dimensions - Taille du plateau (mm) - Размеры противней (мм)	400x600	530x650 500x700
Tepsi Sayısı - Number of Tray - Nombre de plateaux (mm) - Количество противней	10	10
Elektrik Gücü - Electrical Power (kW) Electrique Puissance (kW) - Электрическая мощность (кВт)	2,7	2,7
Ağırlığı - Weight - Poids Du Four (kg) - Вес (кг)	120	130
Elektrik Voltajı - Electric Voltage Tension électrique - Электрическое напряжение	220	220

## ROTARY CONVECTION OVEN DÖNER KONVEKSİYONLU FIRIN

# B2B

KROM TİPİ	AISI 304
KABLO TİPİ (GAZLI)	5x2,5
KABLO TİPİ (ELEKTRİKLİ)	5x4
SİGORTA (GAZLI)	32A
SİGORTA (ELEKTRİKLİ)	63A
MİLİBAR	21-300
REZİSTANS	ATPO 40 14 ADET
	ATPO 50 16 ADET



SAC KALINLIĞI  
1mm (FIRIN DUVARLARI) – TÜM MAKİNE 0.8mm-15mm

DİJİTAL KONTROL PANELİ

ACİL STOP BUTONU

KAPI KOLU

MAYALAMA KABİNİ

REDÜKTÖR  
0.25 kW / 1500 d/dk (4.5 devir)

SİRKÜLASYON FAN MOTORU  
FAN MOTORU: 0,75 kW / 1500 d/dk

BUĞU FANI  
220 W

ANA BACA

TAHLİYE BORUSU

BRÜLÖR

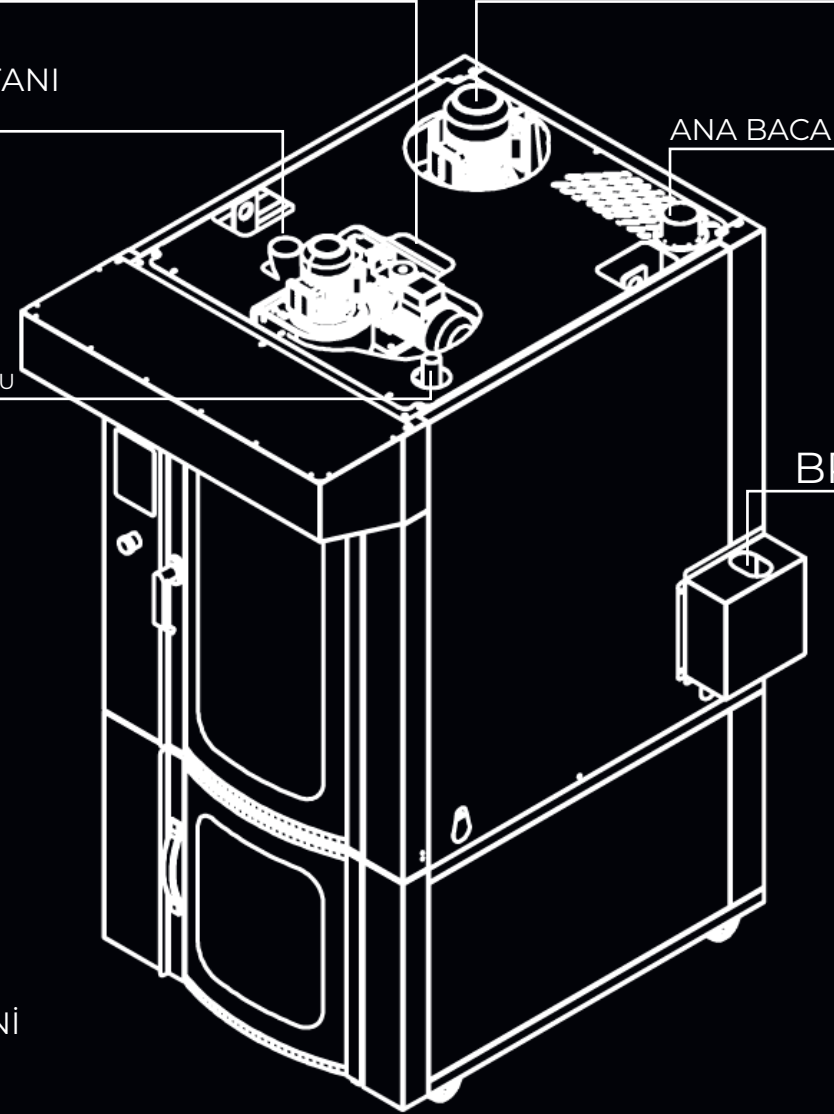

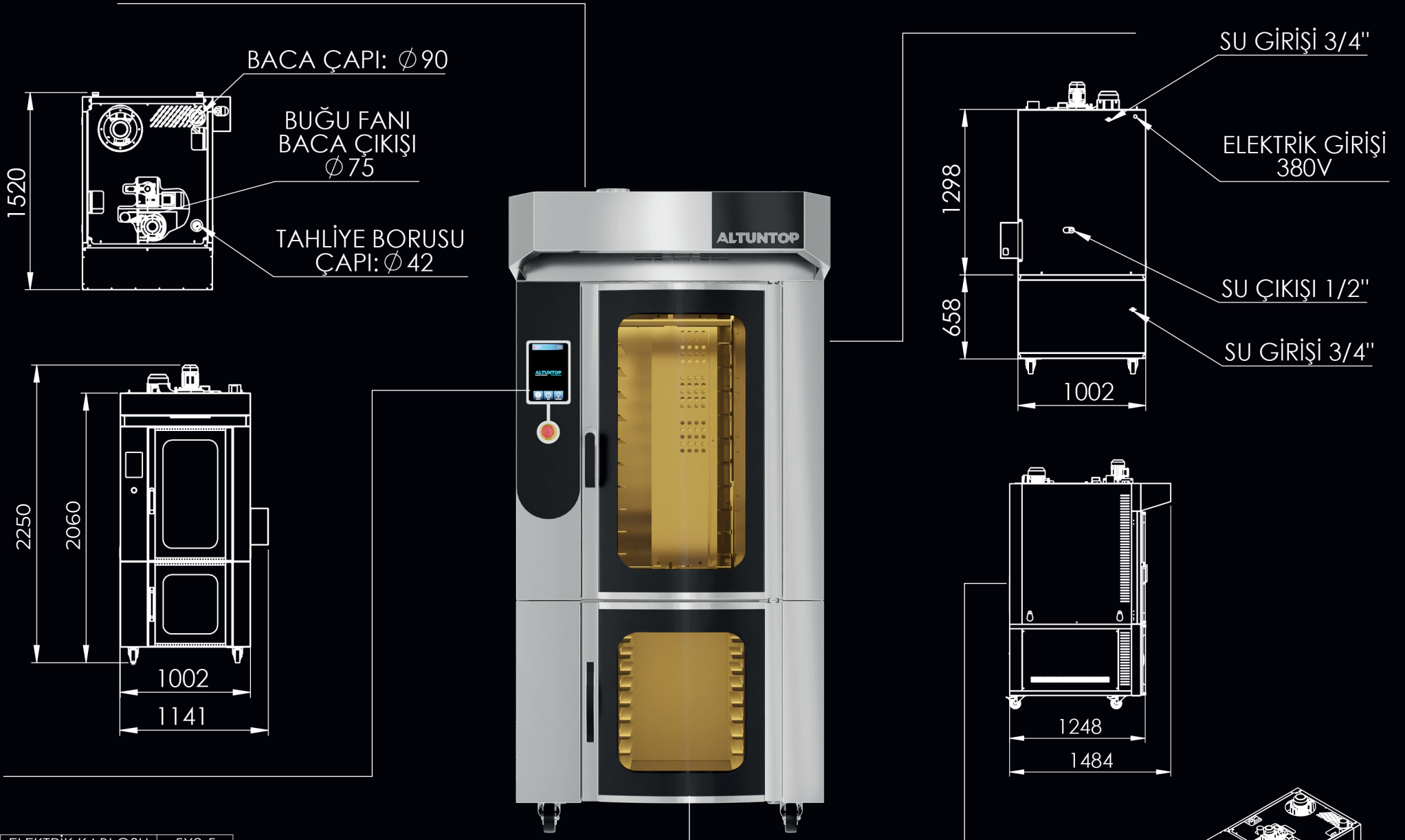

ELEKTRİK KABLOSU	5X2.5
ELEKTRİK GÜCÜ (FİRİN)	1.7 kW
ELEKTRİK GÜCÜ (MAYALAMA)	2.7 kW
TOPLAM ELEKTRİK GÜCÜ	4.4 kW

**ATPD 40**  
(DOĞALGAZLI)

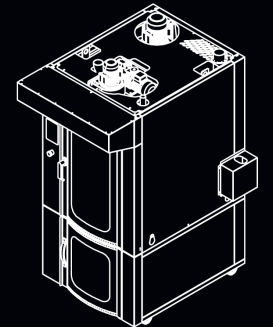

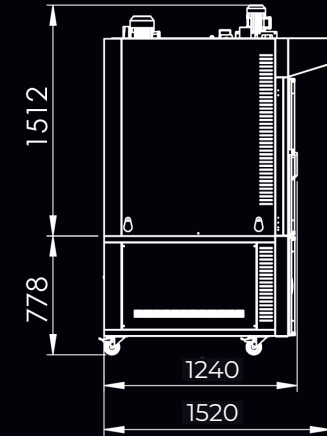
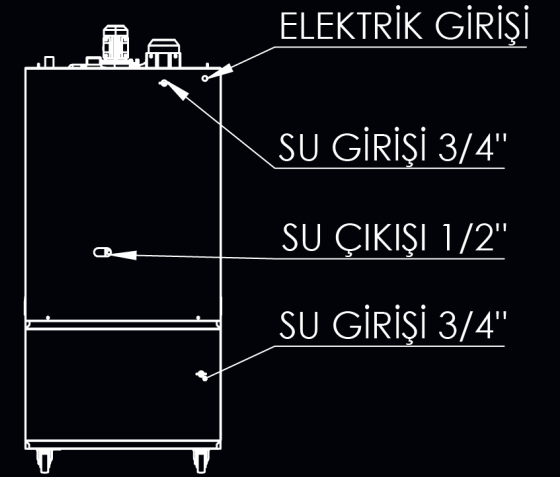
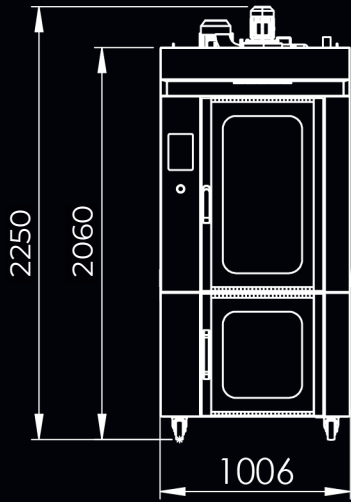
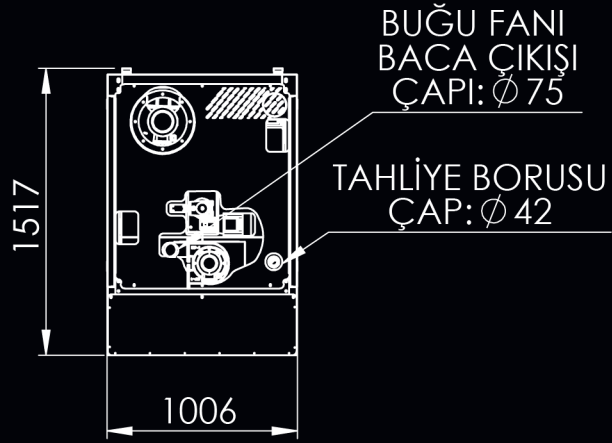

ELEKTRİK KABLOSU	5X4
ELEKTRİK GÜCÜ (FİRİN)	21 kW
ELEKTRİK GÜCÜ (MAYALAMA)	2.7 kW
TOPLAM ELEKTRİK GÜCÜ	23.7 kW

**ATPD 40**  
(ELEKTRİKLİ)

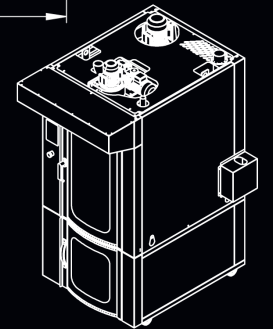

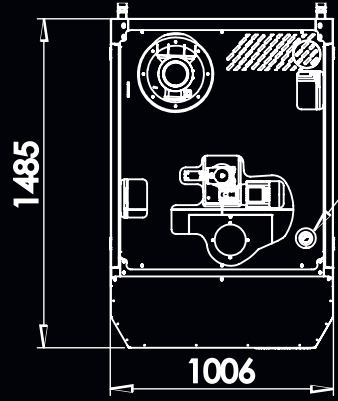

TAHLİYE BORUSU  
ÇAP: Ø 42

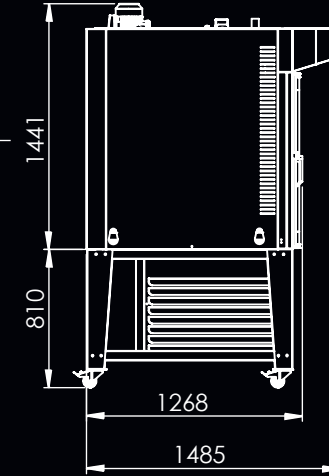
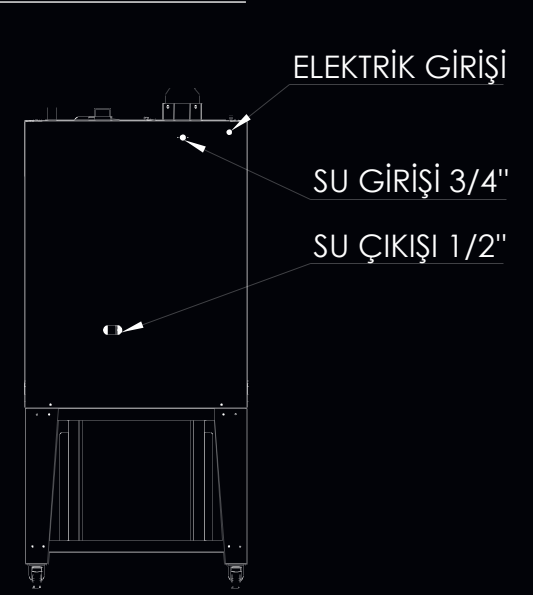
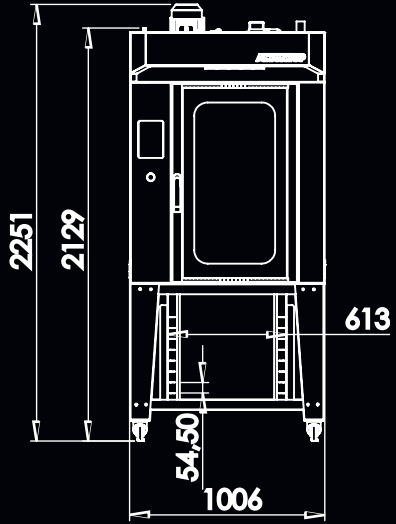

ELEKTRİK KABLOSU	5X4
ELEKTRİK GÜCÜ (FİRİN)	21kW
ELEKTRİK GÜCÜ (MAYALAMA)	2.7 kW
TOPLAM ELEKTRİK GÜCÜ	23.7 kW

**ATPDE 40**  
(SEHPALI)

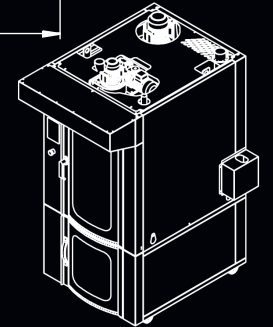

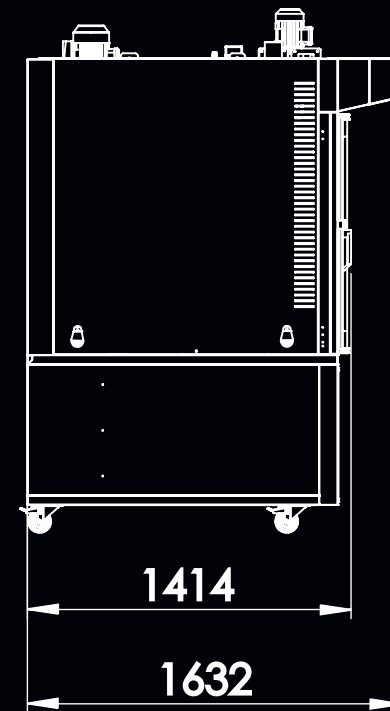
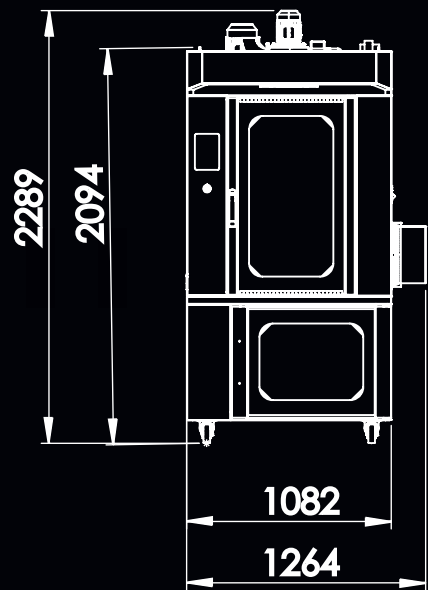
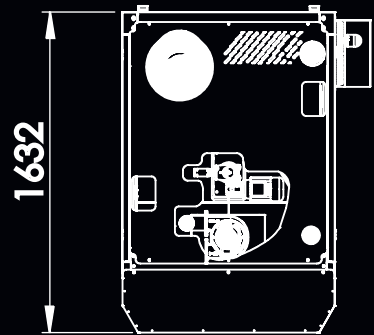

**ATPD 50**  
(DOĞALGAZLI)

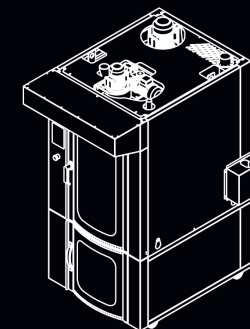



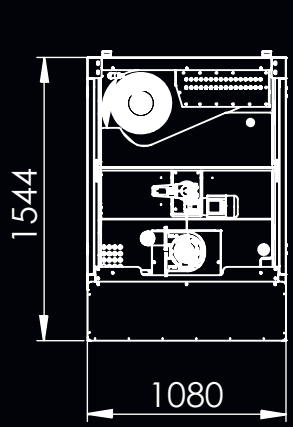

BUĞU FANI  
BACA ÇIKIŞI  
ÇAPI: ● 75

TAHLİYE BORUSU  
ÇAPI: ● 42

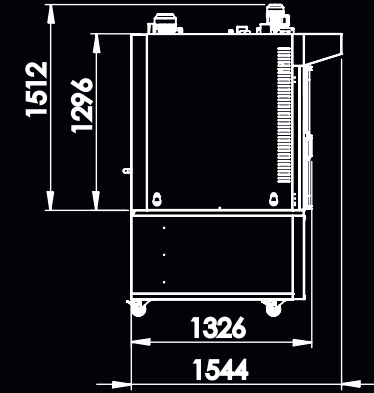
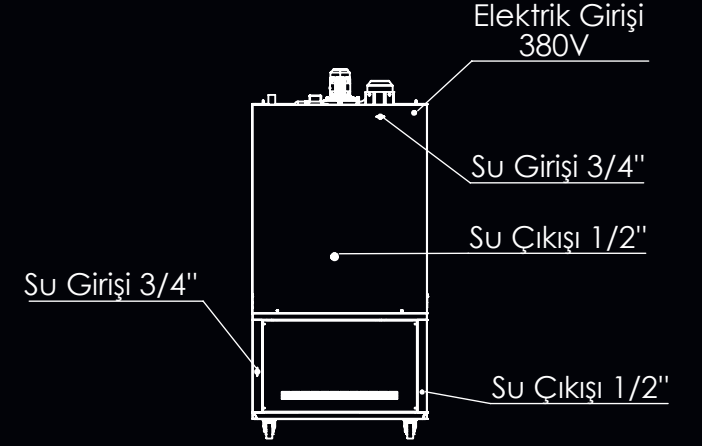
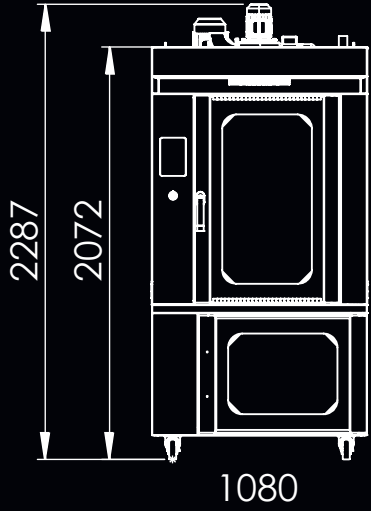

ELEKTRİK KABLOSU	5X4
ELEKTRİK SARFIYATI (FIRIN)	21.5kW
ELEKTRİK SARFIYATI (MAYALAMA)	2.7 kW
TOPLAM ELEKTRİK SARFIYATI	24.2 kW

**ATPD 50**  
(ELEKTRİKLİ)

